

Silverson powder/liquid mixers

Silverson has over 60 years' experience in powder/liquid mixing and offers mixers for a wide range of materials and batch sizes.

The new **Flashmix** is a modular unit that provides a simple, effective and sanitary means of incorporating powders into liquids, even at higher viscosities and at elevated temperatures.

The **Flashblend** is a semi-automated system designed for bulk powder dispersion and ultra-sanitary applications.

The Silverson approach to powder/liquid mixing offers a number of advantages:

Repeatability

Most problems that occur when adding powders into liquids are typically due to operator error - for example adding powders too quickly. With a Silverson mixer the machine dictates the powder addition rate, so repeatability is assured and a consistent homogeneous product will be produced time after time.

Speed

Powder incorporation rates of up to 500 lbs/min substantially reduce process times compared with conventional methods of powder dispersion.

Minimum aeration

Careful attention to design and the speed of powder incorporation ensures that aeration is kept to an absolute minimum. Ideal even for products that tend to foam or aerate easily.

Improved vessel hygiene

Powder is fully dispersed before it enters the mixing vessel, preventing the build-up of partially hydrated powder on the vessel wall that can be encountered when using an in-tank agitator or mixer to disperse powders.





Typical powder dispersion applications

Food industry:

Gum dispersions: Xanthan, Guar, Acacia, etc.

Sugar solutions

Ice cream: Milk powder, Sugar, Cocoa, Stabilizers, etc.

Yogurt: Milk powder, Sugar, Pectin, Gelatin, etc.

Baby milk: Skimmed milk powder, Lactose, Soya protein, Maltodextrin, Fat

Flavored milk drinks: Milk powder, Cocoa, Chocolate crumb, etc.

Soups: Starch, Milk powder, Powdered cream, etc.

Sauces and dressings: Starch, Xanthan gum, Guar gum, Alginates, CMCs, etc.

Flavorings: Acacia gum

Low fat spreads: Caseinates, Gelatine, Starch, etc.

Standardization of milk: Milk powder, Lactose

Sweetened condensed milk: Sugar, Milk powder

Jams and preserves: Pectin solutions

Pet foods: Starch, Guar gum, Xanthan gum, Alginates

Pharmaceuticals

Tablet coatings: Polymer dispersions

Contact lens solutions: Thickening agents, Salts, etc.

Nutrient broths and media: Yeast extracts, Proteins, Sugars, Minerals, etc.

Syrups and linctus: Sugar, Thickening Agents, Active ingredients

Oral suspensions: Thickening agents, Active ingredients

Cosmetics and toiletries:

Carbopol dispersions

Hair gels: Carbopol

Hairsprays and mousses: Resin into alcohol

Shampoos: Sodium Laureth Sulphate (SLES) into water

Deodorants: CMC, Active ingredients

Dental adhesives: Polymer dispersions

Beverage and brewing:

Soft drinks: CMC, Pectin, etc.

Beer: Head retaining agents, Finings

Cream liqueurs: Caseinates, Sugar

Chemical and petrochemical:

Fumed silicas into oils, Resins and water

Specialty chemicals: Crystalline powders into solvents

Drilling muds: Continuous production of Bentonite muds

Oil Blending: Incorporation of lime, etc.

Agrochemicals:

Suspending agents: Bentonite, Xanthan gum, etc.

Dispersion of active ingredients

Flashmix powder/liquid mixing system

The new Silverson Flashmix takes a revolutionary approach to powder/liquid mixing. Unlike many powder/liquid mixers, which use vacuum to pull in powders, the Flashmix literally forces powder into the liquid stream. This not only allows it to disperse and hydrate large

volumes of powders, it means it can be used at higher temperatures and with higher viscosity mixes - offering the advantages of high shear mixing to a wide range of applications that were previously not possible.

Advantages

- Fast powder incorporation rates of up to 500 lbs/min.
- Agglomerate-free, consistent product, time after time.
- Suitable for operation at higher temperature.
- Suitable for higher concentrations of gums and thickeners.
- Minimum aeration.
- Sanitary - the Flashmix is based on an EHEDG and 3-A Certified sanitary mixer.
- Modular construction with a range of options to suit requirements.
- Low power requirement; no additional pump required.
- Low level, ergonomic design.
- Simple - the Flashmix is easy to install, easy to operate and easy to clean.

PATENT PENDING



Flashmix operating principle

The Silverson Flashmix offers a unique method of incorporating powders into liquids, producing an agglomerate-free and homogeneous product:

Stage 1

The self-pumping Flashmix recirculates liquid from the process vessel through the rotor/stator workhead at high velocity.

Stage 2

The powder feed valve is opened, and the high pumping action of the mixer forces the powder into the liquid stream.

Stage 3

The powder and liquid components are introduced straight into the high shear zone of the mixer, and are instantaneously combined as they are subjected to intense mechanical and hydraulic shear. The resultant mix is pumped back into the vessel.

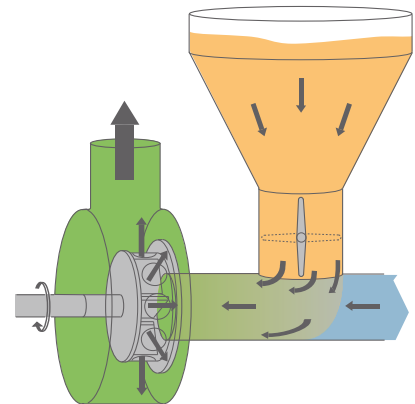
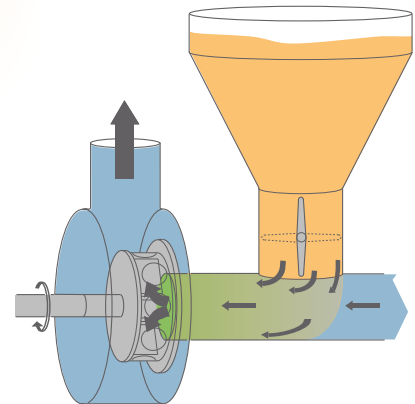
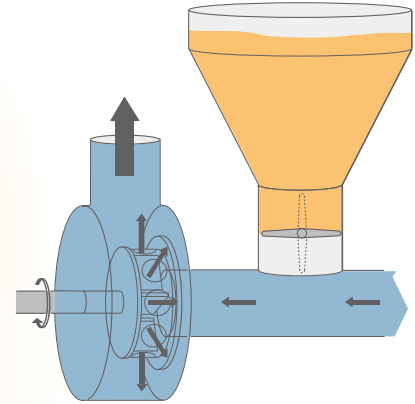

Flashmix operation and performance

Operation

The Flashmix is designed for use in a recirculation system as shown. Powder is rapidly incorporated by the self-pumping Flashmix, and a brief period of recirculation results in an agglomerate-free, homogeneous dispersion.

An auxiliary in-tank mixer or agitator will normally be required to maintain uniformity in the process vessel.

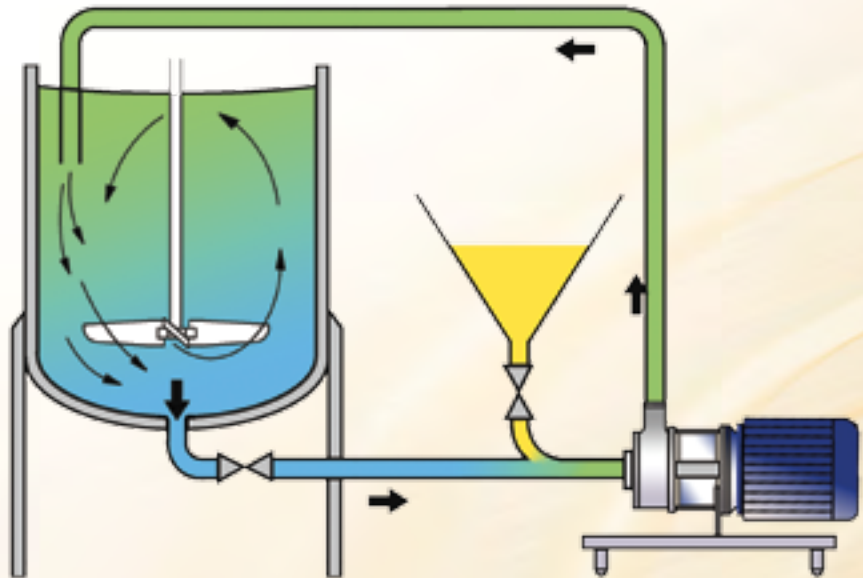

Performance

Typical liquid flow and powder incorporation rates are given in the table.

Model	Liquid flow rate (gallons/min)	Typical powder incorporation rate (lbs/min)		
		Gums & thickeners	Milk proteins	Sugars
FMX25	120	25	90	40
FMX50	230	48	255	80
FMX75	375	165	460	380

Figures given are based on repeated practical testing and represent typical values for guidance only.

Technical specifications and options

Materials of Construction

All product contact parts are in 316L stainless steel. The chassis is constructed from 304 stainless steel.

Motor specifications

TEFV (Totally Enclosed Fan Ventilated) motors are available as standard. Other types of motor and enclosures are available as options.

Inlet and outlet connections

Tri-clamp fittings are standard. Other fittings on request.

Sealing

Hygienic single mechanical shaft seals are standard. Double mechanical shaft seals available.

Valves

Manual butterfly valves are standard.

Cleaning

Designed for Cleaning-In-Place (CIP).

Hopper

Various hoppers are available according to model and application, including profiled hopper for minimal aeration.

Sack Table

A stainless steel sack table is available for FMX25 and FMX50.

Automation

As an optional extra the Flashmix can be supplied with pneumatic valves coupled to a powder sensor for semi-automatic processes.



FMX25 with 1.4 cu ft hopper and manual valve



FMX50 with 3.5 cu ft hopper and manual valve



FMX75 with 10.6 cu ft hopper, pneumatic valve and powder sensor